

DEKCASSETTE SPECIAL

DEKCASSETTE®

FACADE CLADDING ELEMENT OF THE DEKMETAL SYSTEM



The **DEKCASSETTE SPECIAL** type of the cassette represents the variation of the DEKMETAL Façade System. This system makes possible to create an attractive, cost-effective, light and resistant cladding of the ventilated facades of the industry, office and civil buildings.

The form and structural design of DEKCASSETTE SPECIAL cassettes enable to create a plain flat square or rectangular rasters without a visible appearance of the anchorage elements what gives the façade an elegant outlook.

The construction and material designs offered with DEKCASSETTE SPECIAL and other related edging elements of the DEKMETAL façade systems enable to bring the building's outlook a wide variety of colour and forms solutions without essential construction constraints.

The design of each type of the DEKMETAL façade cladding system is adjusted to the implementation of thermal insulation matched with technical requirements on advanced thermal insulation engineering.

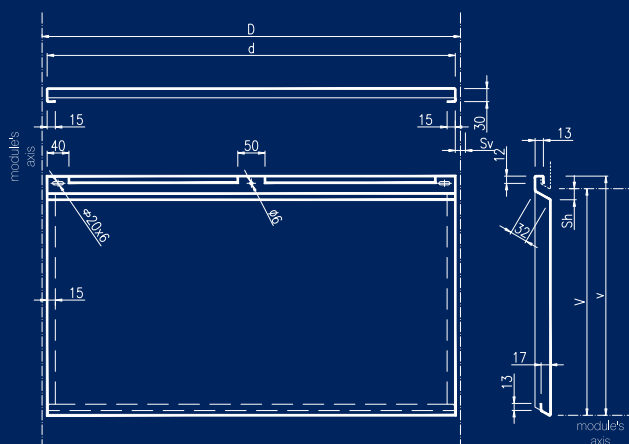

DEKCASSETTE SPECIAL

DESCRIPTION

The facade cassette **DEKCASSETTE SPECIAL** represents a bent square or rectangular element equipped with interlocking locks which are fastened with bearing grid with screws. A down cassette edge is to be inserted into a lock of an already fastened cassette. An upper edge shall be screwed with the bearing grid. Thanks to the fact that the terminal screws are hidden in the cassette lock, a regular raster of elegant gaps on the facade is being created. A width of the vertical gaps can vary from 5 up to 50mm. During the assembly, the surface of the cassettes is protected with a protective film.

DIMENSIONS OF CASSETTES:

Structural length D (mm)	$d + S_v$
Total length d (mm)	min. 150 max. 1950
Structural height V (mm)	min. 150 max. 500
Total height v (mm)	$V + 22 + S_h$
Depth (mm)	30
Horizontal gap S_h (mm)	10 ... 30
Vertical gap S_v (mm)	5 ... 50
Tin thickness	1,00

MATERIALS AND SURFACE FINISHING

Basic materials are varnished zinc-coated steel sheets (tin S250 -320GD + Z275 fitted with polyester varnish of thickness 25 and 35 μm according to the chosen type of the surface adjustments) with both glossy and matte colour shades. There is an option to deliver also specific surface adjustments and „décor“ like e.g. the imitation of wooden stone claddings, metallic colours which may crystalically vary, or different degrees of patinated copper, titanium-zinc or corten. There is also possible to process the cassettes from non-ferrous tins (copper, aluminium, titanium-zinc) being delivered in natural, varnished or weathered fitting. These fittings give the facade cassettes very specific and in some cases unparallel appearances.

DEKMETAL FACADE SYSTEM

Legend:

- 01 - Bearing structure
- 02 - Suspension bracket (console)
- 03 - Profile Z50
- 04 - Diffusional open scruple against wind
- 05 - Thermal insulation from solid planks made from mineral fibres
- 06 - Varnished profile OM80
- 07 - Zinc-coated profile OM50
- 08 - Water bar
- 09 - DEKCASSETTE SPECIAL (DEKCASSETTE LE) (DEKCASSETTE STANDARD) (DEKLAMELLA) (DEKPROFILE)

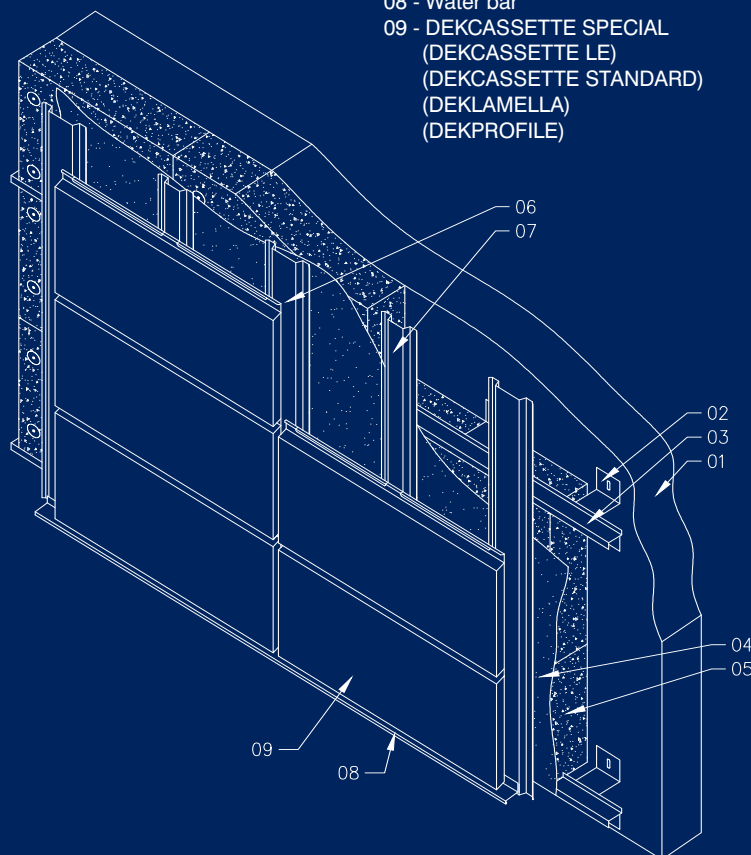

An integral form part of the DEKMETAL facade system form also the additional elements without static functions. It's all about corners cover profiles, steel lining, flashing of attic, weather moldings, ventilation grills, etc. These elements may vary in format according to customer's requirements.

Self-supporting roofing and cladding products from metal sheets of DEKMETAL comply with the harmonised European standard EN 14782. As far as those products manufactured from steel DEKMETAL complies also with the European standard EN 508-1.

More information in detail about further system elements are contained in individual data sheets and assembly documents which can be downloaded from www.dekmetal.cz or www.dekmetal.eu free.

CONTACTS

DEKMETAL

www.dekmetal.eu | www.dekmetal.cz | www.dekmetal.de

DEKMETAL s.r.o.

Tiskarska 10/257
108 00 Praha 10
Czech Republic
Phone: +42/0326971775
info@dekmetal.cz

DEKMETAL GmbH

Franz-Lehman-Str. 27
01139 Dresden
Deutschland
Handy: +49/1748540121
info@dekmetal.de