

ASSEMBLY INSTRUCTIONS

These instructions are intended for mounting the grid system on a flat board homogenous wall structure (eg. brick or concrete wall). Installation on another type (eg. Lightweight steel construction) are dealt with by separate assembly instructions contained within the project documentation. Before starting installation, we must check the flatness of the existing façade. It is necessary to identify the most prominent places on the façade as well as any possible unevenness in these places, as well as in the corners of the façades in order to decide on the the correct lengths of brackets to use, as well as how to rectify any errors. For the installation work, we recommend the use of adjusting pliers

Procedure for the two-way grid DKM2A, and the one-way horizontal grid DKM1B (with type A consoles)

- According to the anchoring plan, individual rows of consoles can be seen in the corners of the building. Bottom row.
- The console brackets are set with the help of a leveling device. Measure out the distance around the brackets with the aid of the dyeing line, and the series is then duplicated on the façade leveling device. Then, measure out the distance around the brackets with the aid of dyeing line again in order to duplicate it on the façade.
- According to the laying plan, fixing is done according to the drawn line on the console. Each bracket is secured with the appropriate anchor bolts.
- Tracing is done at the extreme vertical lines using a plumb line or vertical laser technology
- Racks should be kept at a minimum of 2 cm behind the entire console. According to the vertical plotted points on the brackets, they are connected horizontally with wire. Thus, the plane will be set for the installation of profi les Z50. (If it is possible to use a rotary laser, then this can be used to stake the plane instead of wires).
- The Profi Z50 is placed on a support bracket, checked for its proper positioning relative to the wire, and each hanging bracket is bolted with two mA self-drilling screws. The distance of the front flange of Profile Z50 from the front bracket must not be greater than 30 mm.
- If the unevenness in the façade is outside the rectification possibilities of Profile Z50, then it is necessary to use the U-shaped element. This element is mounted on a horizontal surface and is kept in place with two screws, so that it fully supports the Z50.
- Set in place with profile Z50 and screwed into position.
- Profile Z50 is connected by overlaps in different variants, namely in hard or dilation - this is addressed and illustrated chapters 1.17.1 and 1.17.2

Next steps for the two-way grid DKM2A - OM mounting profiles

- Before beginning installation of the OM profiles, the supplier of these materials recommends that thermal insulation and diffusion films should be installed.
- The placement of OM profiles is governed by the layout plan of the building. Before installation, check that the layout plan corresponds to the building's readiness, and that the edges of the building and construction holes comply with the prescribed distances in the drawings of the details.
- The OM profiles are connected either rigidly or by dilatation. Procedures and rules are determined and shown in chapters 1.17.1 and 1.17.2.
- Individual OM profiles must be in a straight line which must be respected, and their verticality axial distance must correspond to the layout plan and the details contained therein.
- The OM profiles, which are located under the joints of the tiles and are visible, must be made of sheet metal with the surface color finish. Some tiles (eg. DEKCASSETTE SPECIAL) are wider than these OM profiles – see: the layout plans

Procedure for the unidirectional vertical grid DKM1A (with brackets of the type L)

- Deployment consoles and J profiles are governed by the layout plan. Before installation, check that the layout plan corresponds to the building's readiness, and that the edges of the building and construction holes comply with the prescribed distances in the drawings of the details.
- According to the layout plan, the use of plumb lines and coloring will set out a single vertical row of consoles.
- The proposed anchor bolts, at this stage, fasten only the two outer brackets for each profile J
- When mounting the track façade shell with the diffusion foil, it is necessary that vertical J profiles be attached to the application of this film.
- After mounting brackets, the line is traced using a plumb vertical. Racks should be kept to a minimum of 20 mm for the entire console. According to the vertical line, the points on the consoles are plotted along the connected wire. Thus will be set the vertical, perfectly level grid, by which it is possible to do an axial profile J50 (80). In the case that it is possible to use a rotary laser, pegging is used as a marker instead of wire.
- Profile J50 (80) is applied to the console. Check its correct position relative to the wire, and each bracket is screwed in place. The distance of the front flange of profile J50 (80), and the front bracket, must not be greater than 35 mm. Each L-bracket is provided with pre-punched holes - one oval and one round. The oval hole is used in the first phase for temporary anchoring, and it allows displacement of the J-profile forwards and backwards about ± 10 mm. After the final setting, anchoring is done with the help of a second screw. The J-section must always be anchored to each of the L-brackets with two screws. It is not permissible to anchor using only one screw.
- Individual J profiles must be in a straight line and must be respected thus. Their verticality axial distance must also correspond to the layout plan and the details contained therein.
- J profiles are connected by overlaps in different variants, namely in hard or dilation forms. This is addressed and illustrated in chapters 1.17.1 and 1.17.2.
- The remaining brackets on each J profile are laid out alternately on the left and right of the profile, and are anchored at their respective distances to the wall
- If there is unevenness in the façade, which cannot be rectified by profile J50, it must be rectified by use of the U shaped rectification element. This element is mounted on the desktop console and held in place with two bolts



STEEL GRID

Basic Construction Element of the façade system DEKMETAL



DESCRIPTION



The grid is an essential component of the DEKMETAL façade system. Together with the visually exposed elements (DEKCASSETTE, DEKLAMELLA and DEKPROFILE), it creates attractive, economical, lightweight and durable cladding ventilated façades for industrial, administrative and civic buildings. When using the façade system DEKMETAL, it is possible to perform thermal insulation of the façade of the building while respecting the latest developments in thermal technology.

The grid Dekmetal is fully certified and it has been issued with the building technical certificate – by the TZÚS, Prague, dp under No. 070-044245. Within the framework of its structural assessment both computational model simulations and experimental physical examinations were carried out in cooperation with the Technical University in Prague [Faculty of Civil Engineering - Experimental Centre].

The grid is used to transfer the load from the visual elements within the wall structure of the building. The grid is assembled from simple point and line elements (brackets and profiles). It is designed to allow any settlement of the building's construction inequalities. Placement of thermal insulation is designed with the aim of eliminating thermal bridges. The grid DKM2A can also be used for other façade cladding (e.g.: Cetra, Cembit, Fundermax, wood or stone tiles or other materials) with a maximum weight of the cladding element, or overall hung track, of 100kg / m². When designing a grid system for these cladding materials, we must respect the rules laid down by the manufacturer for each material. Deployment of support brackets for such use must be consulted with technical department of Dekmetal. Supporting DEKMETAL grids are made of galvanized steel sheets DX51D + Z275, and are accompanied by a colored organic coating which improves their long-term resistance to weathering.

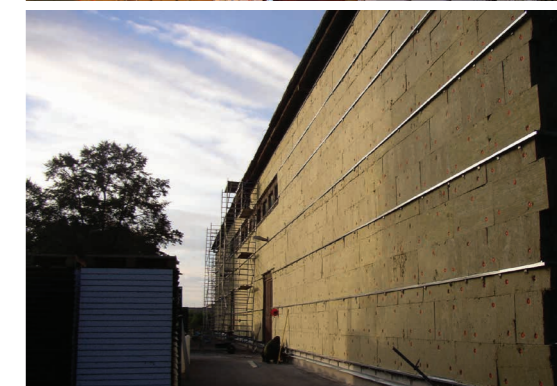

CONTACTS

CZECH REPUBLIC

info@dekmetal.cz

GERMANY

info@dekmetal.de

SLOVAKIA

slovensko@dekmetal.sk

POLAND

info@dekmetal.pl

For a detailed breakdown of individual regions and contact details for our sales managers, please see the Contacts section on the website:

www.dekmetal.com

BASIC TYPES

DKM1A

DKM1B

DKM2A

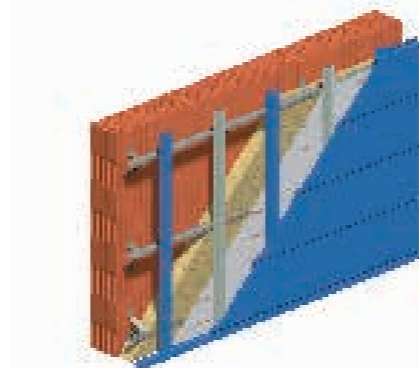
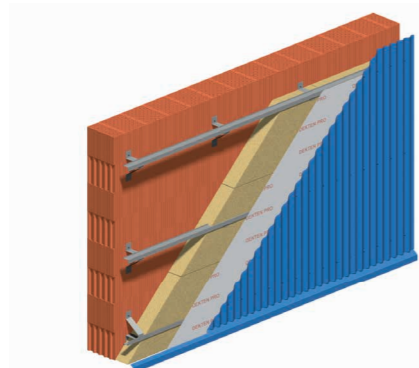
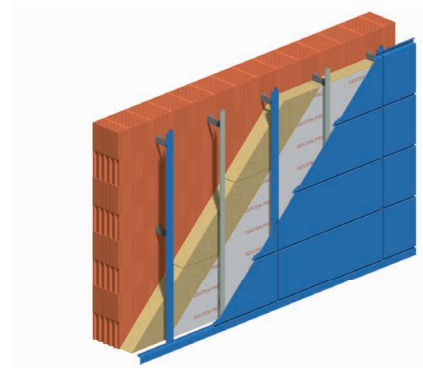

	unheated ventilated jacket	Insulated ventilated casing for airtight (i.e. silicate) walls	Insulated ventilated casing for non-airtight (e.g. lightweight steel) walls
DEKCASSETTE	DKM1A	DKM2A nebo DKM1A	DKM2A
DEKLAMELLA	DKM1A	DKM1A nebo DKM1A	DKM2A
DEKPROFILE - horizontal	DKM1A	DKM1A	DKM2A
DEKPROFILE - vertical	DKM1B	DKM1B	DKM1B

GRID TYPES AND THEIR ELEMENTS

	DKM2A	DKM1A	DKM1B	DKM2A
1st layer line elements	Ground fixed	console A	console L	console A
	Rectification and extension (if necessary)	rectification U	rectification U	rectification U
	DEKCASSETTE IDEAL, (SPECIAL, LE)	profile Z50	profile J50 or J80	-
	DEKCASSETTE STANDARD			
	DEKLAMELLA			
	DEKPROFILE horizontal			
DEKPROFILE vertical	-	profile Z50	2nd layer line elements	profile OM50 or OM80

SECTIONAL CHARACTERISTICS' PROFILES

Type	Full cross-section					Effective cross section				Pressure A _{eff} mm ²
	A mm ²	G kg/m	I _y mm ⁴	I _z mm ⁴	D _{yz} mm ³	Bend		Negative moments		
						Positive moments		Negative moments		
						W _{eff,y} mm ³	W _{eff,y,min} mm ³	I _{eff,y} mm ⁴	W _{eff,y,min} mm ³	
Z50	96,0	0,75	34772,8	12164,5	-13401,0	34772,8	1101,0	30856,6	1050,1	80,4
Z65	104,0	0,82	60418,0	7148,5	-13091,4	60418,0	1577,6	55583,3	1519,8	85,0
J50	113,0	0,89	31241,3	39570,2	20025,4	8171,7	311,2	30343,8	768,8	75,5
J50S	100,0	0,79	14445,8	36045,8	12375,0	5349,3	234,0	14107,0	453,9	75,2
J80	143,0	1,12	35171,5	122783,8	-36685,3	7828,0	295,5	32321,6	792,8	74,6
J80S	130,0	1,02	16115,6	111593,9	-22153,9	5345,0	229,1	15013,1	467,2	74,7
OM50	181,3	1,42	29755,0	245704,5	0,0	28425,4	1804,8	29696,1	1816,3	173,0
OM50/40	201,8	1,58	56220,0	311100,0	0,0	51340,0	2251,0	48680,0	2377,0	184,3
OM80	211,3	1,66	36622,1	459643,5	0,0	34430,6	2063,8	32674,0	2129,3	180,5
OM80/40	231,8	1,82	68510,0	554000,0	0,0	542220,0	2448,0	57650,0	2457,0	192,1

ELEMENTS

CONSOLE

type	x (mm)	y (mm)	z (mm)
console A60	60	73	212
console A80	80	98	226
console A100	100	122	240
console A120	120	146	254
console A140	140	171	268
console A160	160	195	282
console A180	180	220	296
console A200	200	245	310

type	x (mm)
console L60	60
console L80	80
console L100	100
console L120	120
console L140	140
console L160	160
console L180	180
console A200	200

PROFILES

type	x (mm)	y (mm)
profile OM50	50	30
profile OM80	80	30
profile OM50/40	50	40
profile OM 80/40	80	40

type	x (mm)	y (mm)
profile J50	50	53
profile J80	80	53
profile J50S	50	40
profile J80S	80	40

type	x (mm)	y (mm)
profile Z50	50	36
profile Z65	65	29